

## Mesas lineales SLDS.2 Linear unit SLDS.2

### Características principales:

- Movimiento modular ajustable con intervalos de 0,1 mm.
- Cilindro neumático con 63, 80, 125 mm de diámetro
- 2 guías lineales y 4 bloques de desplazamiento
- Repetibilidad :  $\pm 0,01$  mm
- Sistema de bloqueo Power clamp (SBC)
- Amortiguador del cilindro en posición hacia atrás
- Amortiguador en la posición delantera
- Interruptores de proximidad en la posición de avance y retroceso
- Tapas o fuelles metálicos

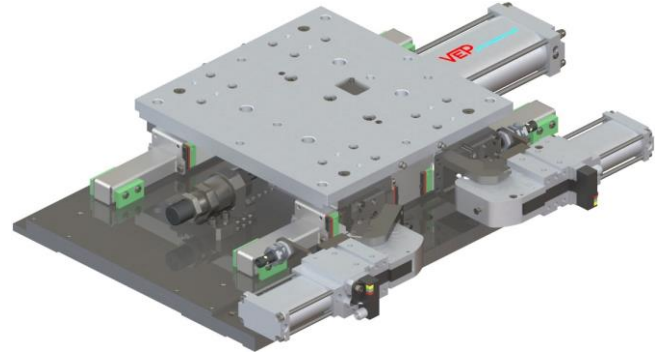

### Main characteristics:

- Adjustable modular stroke 0,1 mm. intervals
- Pneumatic cylinder with 63, 80 and 125 mm. bore
- 2 linear rails and 4 runner blocks
- Repeatability :  $\pm 0,01$  mm.
- Power Clamp locking system (SBC)
- Cylinder cushioning in the backwards position
- Shock absorber in the forward position
- Proximity switches in the backwards and forward position
- Metal covers or bellows



[PDF](#)



[3D Step](#)



[Index](#)

### Índice.

### Index.

Página Page	Descripción Description	
1	Características principales <a href="#">Main characteristics</a>	
2	Ejemplo de pedido <a href="#">Ordering example</a>	
3-4	Página dimensional <a href="#">Dimensional page</a>	SLDS63.2
5-6		SLDS80.2
7-8		SLDS125.2
9	Diagrama de sensor inductivo CP40.3 - CP50.1 <a href="#">Inductive sensor diagram for CP40.3 - CP50.1</a>	
10	El límite de la unidad lineal cambia el diagrama / Diagrama Neumático / consumo de Aire <a href="#">Linear unit limit switch diagram / Pneumatic plan / Air consumption</a>	
11-12	Piezas de repuesto / <a href="#">Spare parts</a>	
13	Notas / <a href="#">Notes</a>	

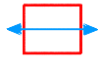

## Codice d'ordine. Ordering example.

SLDS80.2	-	100/60	-	L	-	S1	-	H
----------	---	--------	---	---	---	----	---	---

**SLDS63.2**  
Cilindro Ø 63 mm., 4 bloques corredor, carga máx. 150Kg  
Cylinder bore Ø 63 mm.,  
4 runner blocks, max. load 150 Kg

**SLDS80.2**  
Cilindro Ø 80 mm., 4 bloques corredor, carga máx. 250 Kg  
Cylinder bore Ø 80 mm.,  
4 runner blocks, max. load 250 Kg

**SLDS125.2**  
Cilindro Ø 125 mm., 4 bloques corredor, carga máx. 600 Kg  
Cylinder bore Ø 125 mm.,  
4 runner blocks, max. load 600 Kg

**Posición del dispositivo de bloqueo SBC :**  
**SBC locking device position :**

**X :** Sin bloqueo / *without locking*

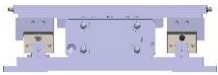

**L :** Bloqueo en el lado izquierdo / *Locking on the left side*  
(Posición de entrega estándar) *Standard delivery position*

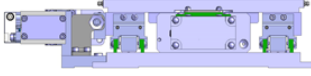

**R :** Bloqueo en el lado derecho / *Locking on the right side*

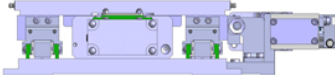

Tipo Type	Carrera ajustable Adjustable stroke
50	5÷50 mm.
100	51÷100 mm.
150	101÷150 mm.
200	151÷200 mm.
300	201÷300 mm.
400	301÷400 mm.
500	401÷500 mm.

**La carrera de la unidad lineal es ajustable con pasos de 0,1 mm.**  
**The stroke of the linear unit is adjustable with steps of 0.1 mm.**

**Tipos estándar / Standard types :**

	50	100	150	200	300	400	500
<b>SLDS63.2</b>	50	100	150	200	300	400	500
<b>SLDS80.2</b>	50	100	150	200	300	400	500
<b>SLDS125.2</b>	50	100	150	200	300	400	500

Tipos 400 y 500 bajo pedido  
Types 400 and 500 on request

**Cobertura :**  
**Cover:**

**X :** Sin cobertura  
*Without cover*

**S1 :** Con cubierta de chapa (estándar)  
*With metal sheet cover (standard)*

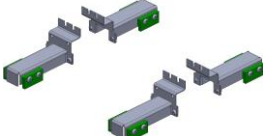

**S4\* :** Con fuelles en la parte delantera y trasera  
*With bellows on the front and back side*



\* La cubierta tipo S4 es una solución especial. Disponible solo previa consulta y aprobación de VEP Automatización.  
\* Cover type S4 is a special solution. Available only after consultation and approval of VEP Automation.

ATENCIÓN → Tapa S4 no disponible para SLDS63.2 carrera 50 mm.  
**ATTENTION → Cover S4 not available for SLDS63.2 stroke 50 mm.**

**Posición de montaje :**  
**Mounting position :**

**H :** Horizontal (estándar)  
*Horizontal (standard)*

**V :** Aplicación especial con posición de montaje vertical (colgante o vertical) **SOLAMENTE** después de la aprobación de VEP Automation  
*Special application with vertical or tilted mounting position **ONLY** after the approval of VEP Automation*

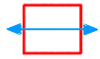

## SLDS63.2-... / ...-X-H

Unidad lineal, D. 63, 4 bloques de desplazamiento, Sistema de bloqueo de brida, Varios movimientos

Linear unit, D. 63, 4 Runner blocks, Clamp locking sys., Various stroke

Orificios de conexión SBC

SBC connection holes

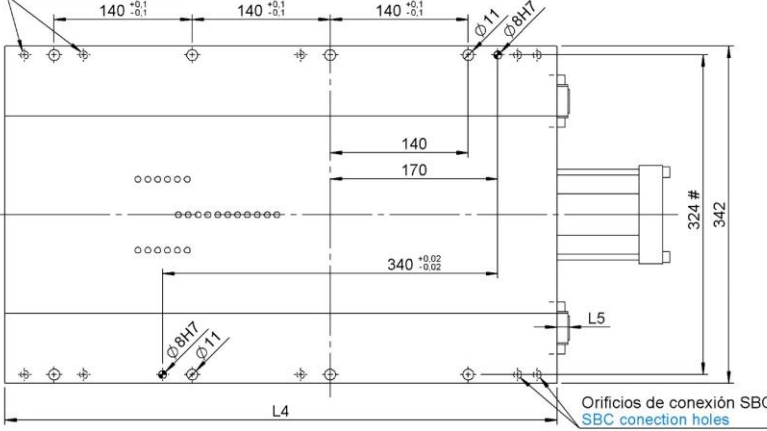

Tapa del vástago del cilindro :

- Disponible con tapa **S1** para tipo **150** y superior

Cylinder rod cover :

- Available with **S1** cover for type **150** and above

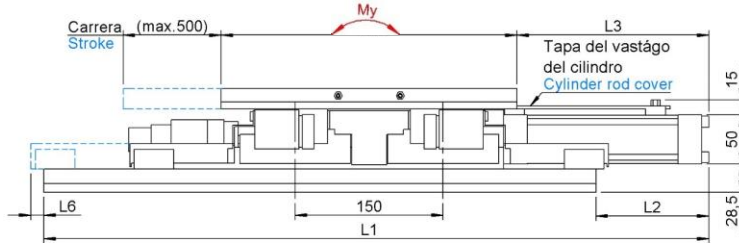

\*\* Carga Max.

\*\* Max. load

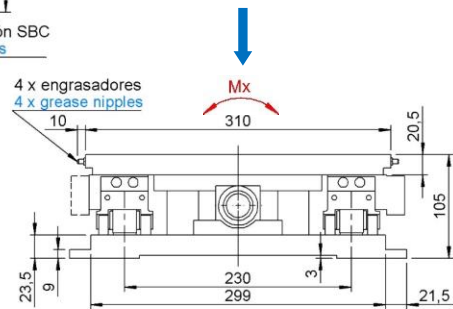

Amortiguador

Shock absorber

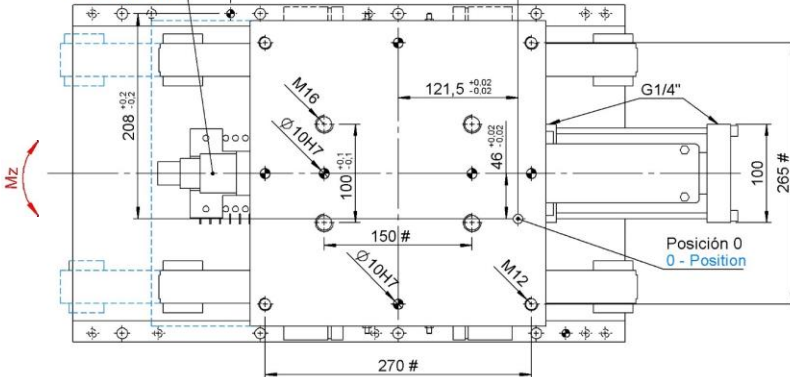

Tolerancias de carrera :

- hasta carrera de 300 mm. : ± 0,03 mm.

- 400 & 500 mm. : ± 0,05 mm.

Stroke tolerances :

- up to stroke 300 mm. : ± 0,03 mm.

- stroke 400 mm. & 500 mm. : ± 0,05 mm.

\*\*\* aplicación especial

SOLAMENTE después de la aprobación

de **VEP Automation**

\*\*\* special application

ONLY after the approval of

**VEP Automation**

#Tolerancias : barrenos ± 0.02, orificios de tornillo ± 0.1

#Tolerances : dowel holes ± 0.02, screw holes ± 0.1

Modelo Type	Tipo Type	D.Cilindro Cylinder bore	Carrera ajustable Adjustable stroke	Peso Weight	L1	L2	L3	L4	L5	Consumo aire (5 bar) Air consumption (5 bar)	Presión de trabajo Working pressure
		[mm.]	[mm.]	[kg]	[mm.]	[mm.]	[mm.]	[mm.]	[mm.]	[l]	[bar]
SLDS63.2-50	50	63	5 - 50	54	625	65	145	560	---	1,9	4 - 8
SLDS63.2-100	100		50-100	54	675	115	195	560	14	3,6	
SLDS63.2-150	150		100-150	62	825	165	245	660	64	5,4	
SLDS63.2-200	200		150-200	62	875	215	295	660	114	7,2	
SLDS63.2-300	300		200-300	70	1075	315	395	760	214	10,7	
SLDS63.2-400	400		300-400	78	1275	415	495	860	314	14,3	
SLDS63.2-500	500	400-500	86	1475	515	595	960	414	17,9		

\*\* Máxima carga aplicable (5 bar)  
\*\* Max. applicable load (5 bar)

Esfuerzo de torsión  
dinámico máximo  
Dynamic torque max

Momento estático  
máximo  
Static moment max.

Max. Fuerza de  
empuje  
Max. Thrust force  
(5 bar)

[kg]		[Nm]			[Nm]			[N]
Instalación horizontal Horizontal installation	Instalación vertical Vertical installation	Mx	My	Mz	Mx	My	Mz	1480
150	65***	560	280	220	840	430	330	

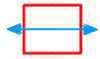

## Unidad lineal con sistema de bloqueo de bridas Linear unit with clamps locking system

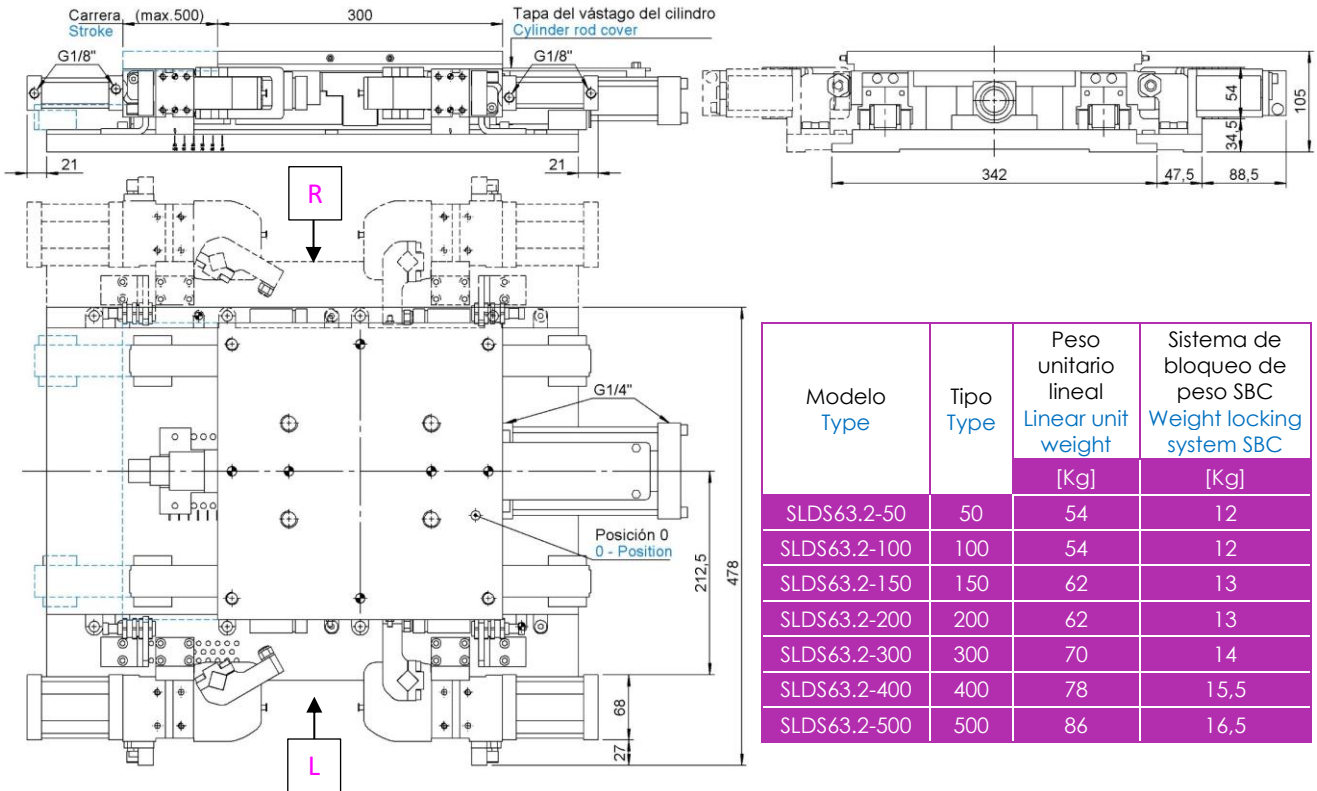

Modelo Type	Tipo Type	Peso unitario lineal Linear unit weight	Sistema de bloqueo de peso SBC Weight locking system SBC
		[Kg]	[Kg]
SLDS63.2-50	50	54	12
SLDS63.2-100	100	54	12
SLDS63.2-150	150	62	13
SLDS63.2-200	200	62	13
SLDS63.2-300	300	70	14
SLDS63.2-400	400	78	15,5
SLDS63.2-500	500	86	16,5

## Ajuste de recorrido deslizante Slide stroke adjustment

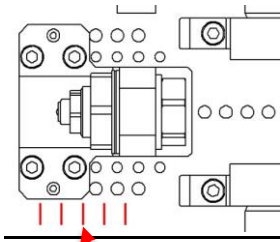

### Ajuste grueso (pasos de 10 mm.)

Tope delantero + amortiguador.  
Al mover el soporte (agujeros en la placa), la carrera deslizante se puede cambiar en incrementos de 10 mm.

### Coarse adjustment (Steps 10 mm.)

Front end stop + shock absorber.  
By moving the bracket (holes on the plate), the slide stroke can be changed in 10 mm. increments.

Modelo Type	Carrera cilindro Cylinder stroke	Recorrido corto Short slide stroke	Recorrido largo Long slide stroke
SLDS63.2-50	50	5 ÷ 50	
SLDS63.2-100	100		51 ÷ 100
SLDS63.2-150	150	101 ÷ 150	
SLDS63.2-200	200		151 ÷ 200
SLDS63.2-300	300	201 ÷ 250	251 ÷ 300
SLDS63.2-400	400	301 ÷ 350	351 ÷ 400
SLDS63.2-400	500	401 ÷ 450	451 ÷ 500

La tabla anterior muestra los distintos tipos de carros con sus carreras máximas y mínimas posibles.

The table above shows the various types of slides with their maximum and minimum possible strokes.

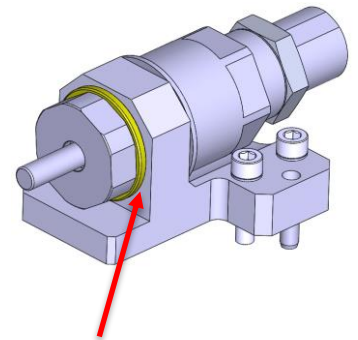

### Microajuste

Con cuñas entre soporte y tuerca anular.  
Al reemplazar/agregar calzas calibradas, se puede modificar la carrera.  
Cuñas estándar de 3/4/5 mm.

### Fine adjustment

With Shims between bracket and ring nut.  
By replacing/adding calibrated shims, the stroke can be modified.  
Standard shims of 3/4/5 mm.

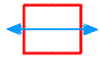

## SLDS80.2-... / ...-X-H

Unidad lineal, D. 80, 4 bloques de desplazamiento, Sistema de bloqueo de brida, Varios movimientos

Linear unit, D. 80, 4 Runner blocks, Clamp locking sys., Various stroke

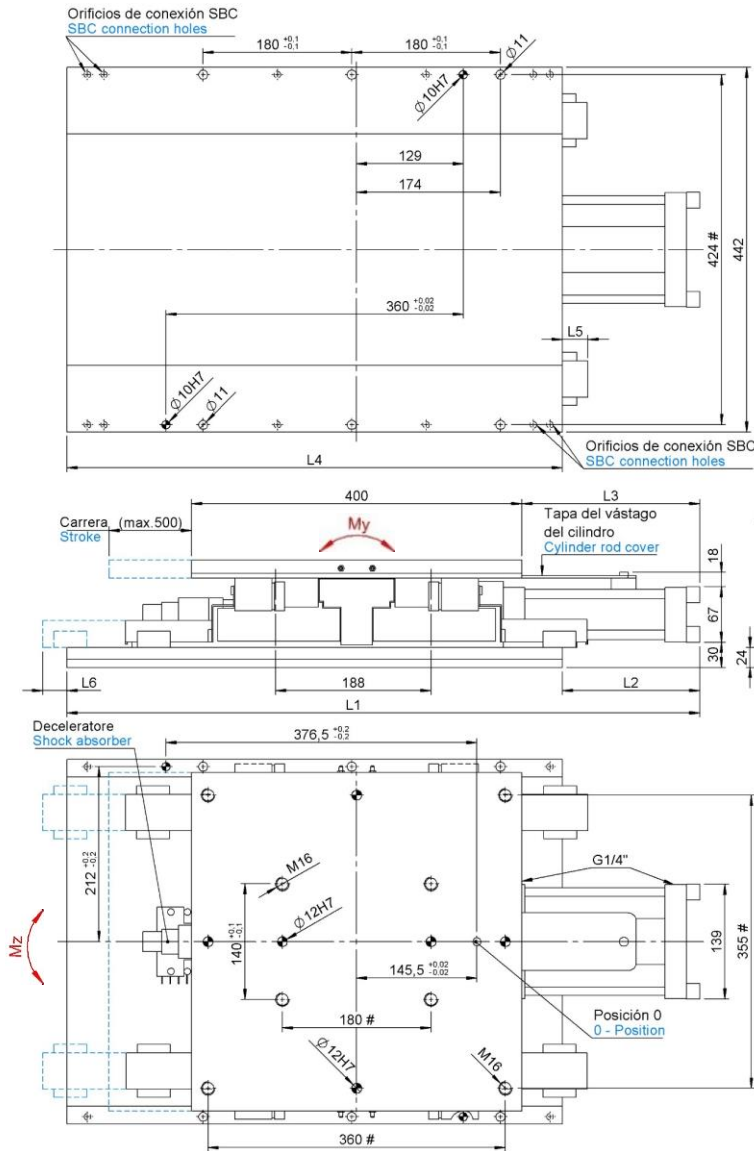

Tapa del vástago del cilindro :  
 - Disponible con tapa **S1** para tipo **150** y superior  
 Cylinder rod cover :  
 - Available with **S1** cover for type **150** and above

\*\* Carga max.  
 \*\* Max. load

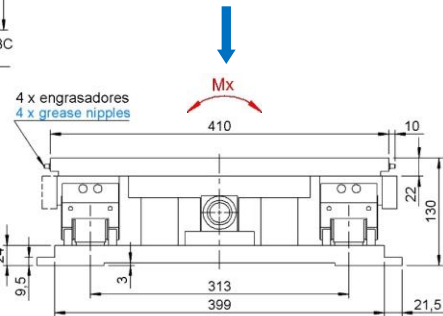

Tolerancias de carrera :  
 - hasta carrera de 300 mm. : ± 0,03 mm.  
 - 400 mm. & 500 mm. : ± 0,05 mm.

Stroke tolerances :  
 - up to stroke 300 mm. : ± 0,03 mm.  
 - stroke 400 mm. & 500 mm. : ± 0,05 mm.

\*\*\* aplicación especial  
SOLAMENTE después de la aprobación de VEP Automation  
 \*\*\* special application  
ONLY after the approval of VEP Automation

#Tolerancias : barrenos ± 0.02, orificios de tornillo ± 0.1  
 #Tolerances : dowel holes ±0.02, screw holes: ±0.1

Modelo Type	Tipo Type	D.Cilindro Cylinder bore	Carrera ajustable Adjustable stroke	Peso Weight	L1	L2	L3	L4	L5	Consumo de aire (5 bar) Air consumption (5 bar)	Presió de trabajo Working pressure
		[mm.]	[mm.]	[kg]	[mm.]	[mm.]	[mm.]	[mm.]	[mm.]	[l]	[bar]
SLDS80.2-50	50	80	5 - 50	90	717	117	166	600	---	3,0	4 - 8
SLDS80.2-100	100		50-100	91	767	167	216	600	30	5,9	
SLDS80.2-150	150		100-150	100,5	917	217	266	700	80	8,8	
SLDS80.2-200	200		150-200	101,5	967	267	316	700	130	11,6	
SLDS80.2-300	300		200-300	112,5	1167	367	416	800	230	17,4	
SLDS80.2-400	400		300-400	124	1367	467	516	900	330	23,1	
SLDS80.2-500	500		400-500	134,5	1567	567	616	1000	430	28,9	

** Máxima carga aplicable (5 bar) ** Max. applicable load (5 bar)		Esfuerzo de torsión dinámico máximo Dynamic torque max			Momento estático máximo Static moment max.			Max. Fuerza de empuje Max. Thrust force (5 bar)
[kg]		[Nm]			[Nm]			[N]
Instalación horizontal Horizontal installation	Instalación vertical Vertical installation	Mx	My	Mz	Mx	My	Mz	2390
250	90***	1270	640	500	1930	980	760	

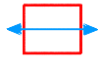

## Unidad lineal con sistema de bloqueo de bridas Linear unit with clamps locking system

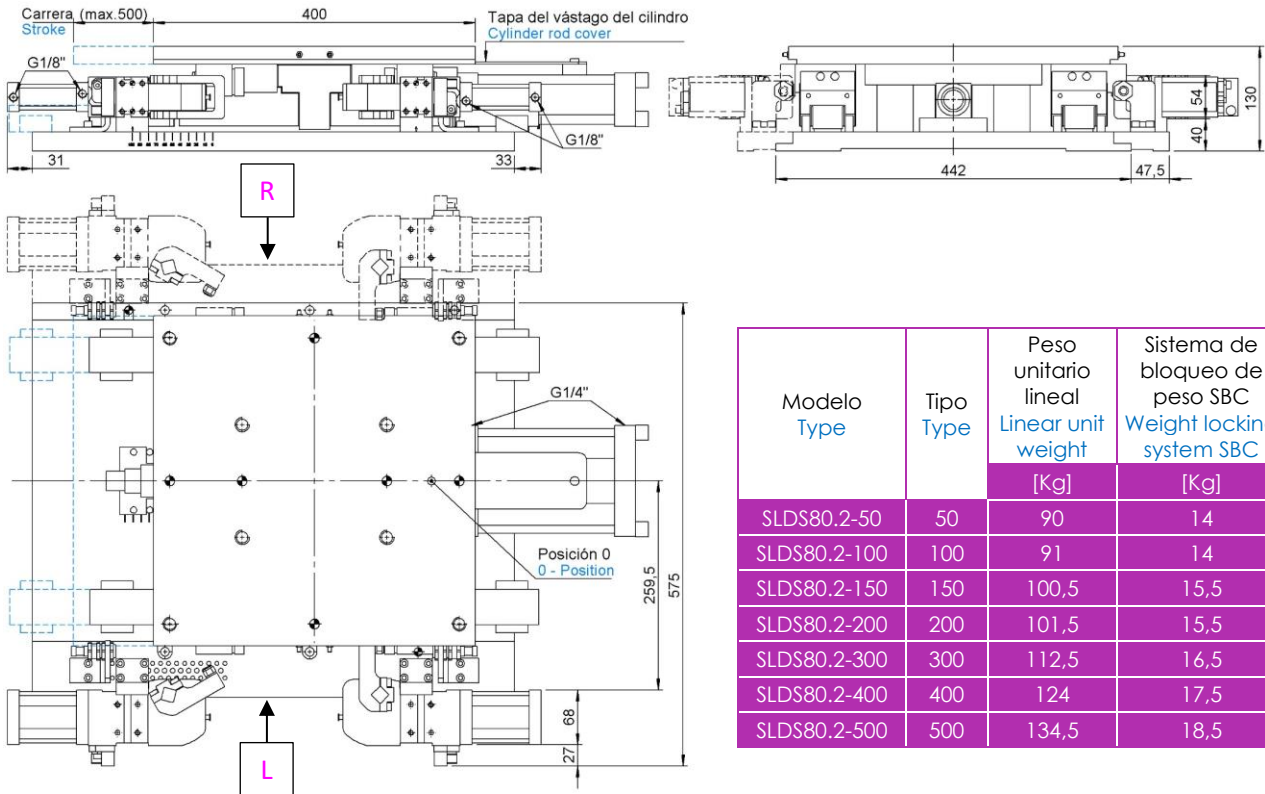

Modelo Type	Tipo Type	Peso unitario lineal Linear unit weight	Sistema de bloqueo de peso SBC Weight locking system SBC
		[Kg]	[Kg]
SLDS80.2-50	50	90	14
SLDS80.2-100	100	91	14
SLDS80.2-150	150	100,5	15,5
SLDS80.2-200	200	101,5	15,5
SLDS80.2-300	300	112,5	16,5
SLDS80.2-400	400	124	17,5
SLDS80.2-500	500	134,5	18,5

## Ajuste de recorrido deslizante Slide stroke adjustment

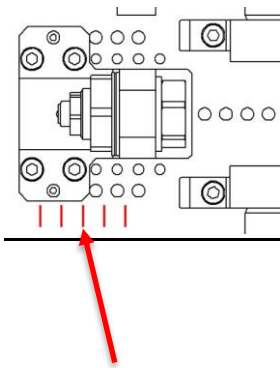

Modelo Type	Carrera cilindro Cylinder stroke	Recorrido corto Short slide stroke	Recorrido largo Long slide stroke
SLDS80.2-50	50	5 ÷ 50	
SLDS80.2-100	100		51 ÷ 100
SLDS80.2-150	150	101 ÷ 150	
SLDS80.2-200	200		151 ÷ 200
SLDS80.2-300	300	201 ÷ 250	251 ÷ 300
SLDS80.2-400	400	301 ÷ 350	351 ÷ 400
SLDS80.2-400	500	401 ÷ 450	451 ÷ 500

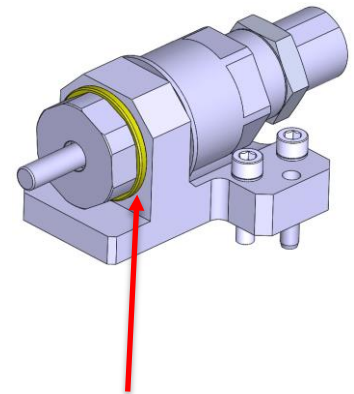

**Ajuste grueso (pasos de 10 mm)**  
Tope delantero + amortiguador.  
Al mover el soporte (agujeros en la placa), la carrera deslizante se puede cambiar en incrementos de 10 mm.

**Coarse adjustment (Steps 10 mm.)**  
Front end stop + shock absorber.  
By moving the bracket (holes on the plate), the slide stroke can be changed in 10 mm. increments.

La tabla anterior muestra los distintos tipos de carros con sus carreras máximas y mínimas posibles.  
The table above shows the various types of slides with their maximum and minimum possible strokes.

**Microajuste**  
Con cuñas entre soporte y tuerca anular.  
Al reemplazar/agregar calzas calibradas, se puede modificar la carrera.  
Cuñas estándar de 3/4/5 mm.

**Fine adjustment**  
With Shims between bracket and ring nut.  
By replacing/adding calibrated shims, the stroke can be modified.  
Standard shims of 3/4/5 mm.

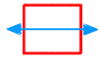

## SLDS125.2-... / ...-X-H

Unidad lineal, D. 125, 4 bloques de desplazamiento, Sistema de bloqueo de brida, Varios movimientos  
 Linear unit, D. 125, 4 Runner blocks, Clamp locking sys., Various stroke

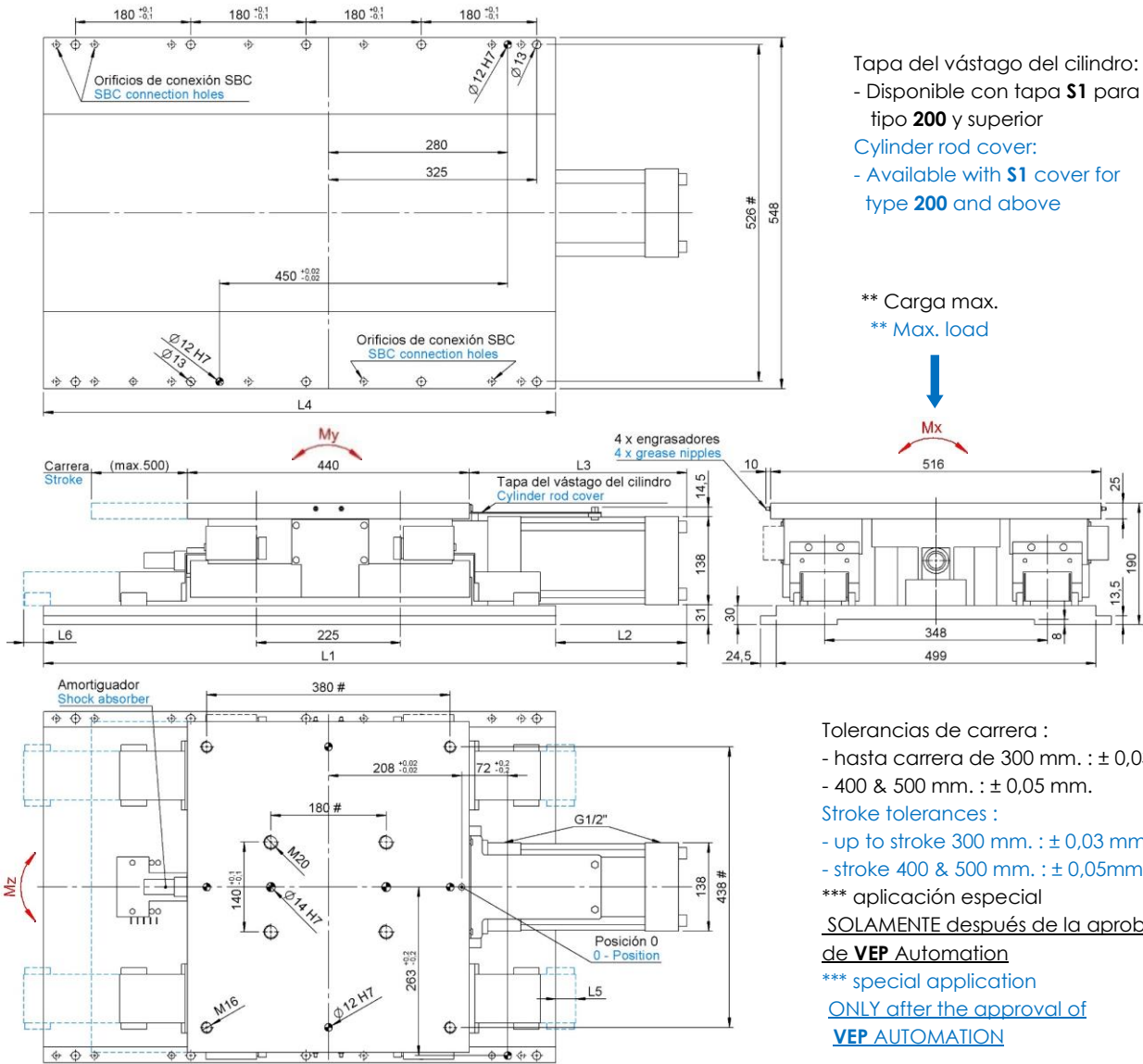

Tapa del vástago del cilindro:  
 - Disponible con tapa **S1** para tipo **200** y superior  
 Cylinder rod cover:  
 - Available with **S1** cover for type **200** and above

\*\* Carga max.  
 \*\* Max. load

Tolerancias de carrera :  
 - hasta carrera de 300 mm. : ± 0,03 mm.  
 - 400 & 500 mm. : ± 0,05 mm.  
 Stroke tolerances :  
 - up to stroke 300 mm. : ± 0,03 mm.  
 - stroke 400 & 500 mm. : ± 0,05mm.  
 \*\*\* aplicación especial  
SOLAMENTE después de la aprobación de VEP Automation  
 \*\*\* special application  
ONLY after the approval of VEP AUTOMATION

# Tolerancias : barrenos ± 0.02, orificios de tornillo ± 0.1 / #Tolerances : dowel holes ± 0.02, screw holes ± 0.1

Modelo Type	Tipo Type	D.Cilindro Cylinder bore	Carrera ajustable Adjustable stroke	Peso Weight	L1	L2	L3	L4	L5	Consumo aire (5 bar) Air consumption (5 bar)	Presi de trabajo Working pressure	
		[mm.]	[mm.]	[kg]	[mm.]	[mm.]	[mm.]	[mm.]	[mm.]	[l]	[bar]	
SLDS125.2-50	50	125	5 - 50	205	955	155	290	800	---	7,8	4 - 8	
SLDS125.2-100	100		50-100	206	1005	205	340	800	---	14,7		
SLDS125.2-150	150		100-150	225	1155	255	390	900	26	21,8		
SLDS125.2-200	200		150-200	225	1205	305	440	900	76	28,7		
SLDS125.2-300	300		200-300	245	1405	405	540	1000	176	42,7		
SLDS125.2-400	400		300-400	265	1605	505	640	1100	276	56,6		
SLDS125.2-500	500		400-500	285	1805	605	740	1200	376	70,6		
** Máxima carga aplicable (5 bar) ** Max. applicable load (5 bar)				Esfuerzo de torsión dinámico máximo Dynamic torque max			Momento estático máximo Static moment max.			Max. Fuerza de empuje (5 bar) Max. Thrust force (5 bar)		
				[kg]			[Nm]			[Nm]		[N]
Instalación horizontal Horizontal installation		Instalación vertical Vertical installation		Mx	My	Mz	Mx	My	Mz	5820		
600		180***		3500	2280	1300	4900	3190	2100			

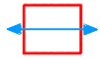

## Unidad lineal con sistema de bloqueo de bridas Linear unit with clamps locking system

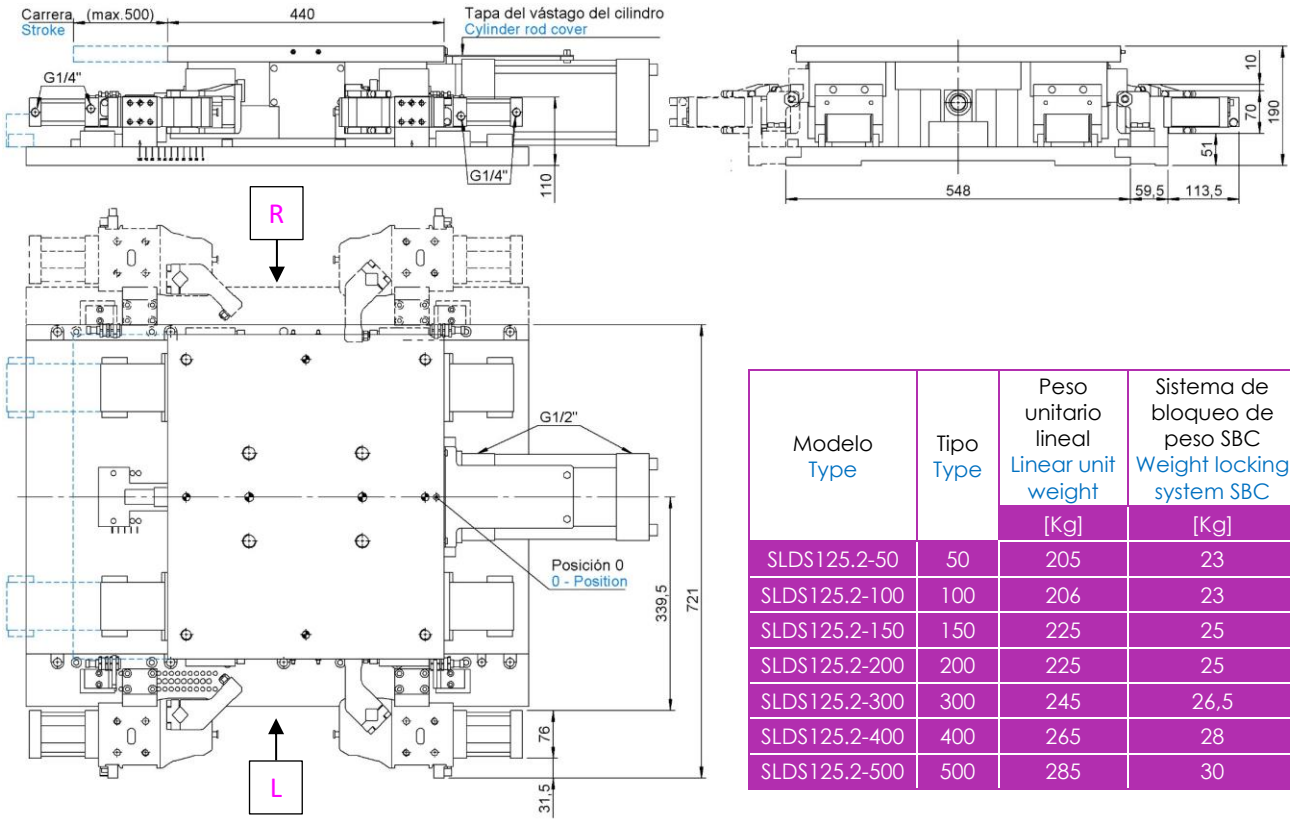

Modelo Type	Tipo Type	Peso unitario lineal Linear unit weight	Sistema de bloqueo de peso SBC Weight locking system SBC
		[Kg]	[Kg]
SLDS125.2-50	50	205	23
SLDS125.2-100	100	206	23
SLDS125.2-150	150	225	25
SLDS125.2-200	200	225	25
SLDS125.2-300	300	245	26,5
SLDS125.2-400	400	265	28
SLDS125.2-500	500	285	30

## Ajuste de recorrido deslizante Slide stroke adjustment

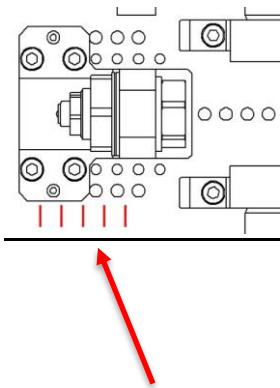

Modelo Type	Carrera cilindro Cylinder stroke	Recorrido corto Short slide stroke	Recorrido largo Long slide stroke
SLDS125.2-50	50	5 ÷ 50	
SLDS125.2-100	100		51 ÷ 100
SLDS125.2-150	150	101 ÷ 150	
SLDS125.2-200	200		151 ÷ 200
SLDS125.2-300	300	201 ÷ 250	251 ÷ 300
SLDS125.2-400	400	301 ÷ 350	351 ÷ 400
SLDS125.2-400	500	401 ÷ 450	451 ÷ 500

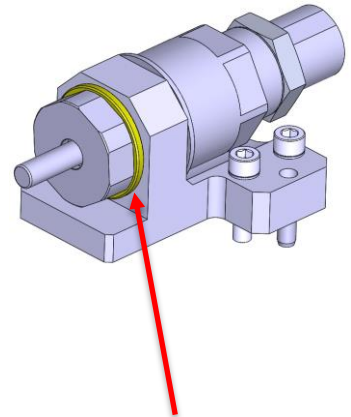

**Ajuste grueso (pasos de 10 mm)**  
Tope delantero + amortiguador.  
Al mover el soporte (agujeros en la placa), la carrera deslizante se puede cambiar en incrementos de 10 mm.  
**Coarse adjustment (Steps 10 mm.)**  
Front end stop + shock absorber.  
By moving the bracket (holes on the plate), the slide stroke can be changed in 10 mm. increments.

La tabla anterior muestra los distintos tipos de carros con sus carreras máximas y mínimas posibles.  
The table above shows the various types of slides with their maximum and minimum possible strokes.

**Microajuste**  
Con cuñas entre soporte y tuerca anular. Al reemplazar/agregar calzas calibradas, se puede modificar la carrera.  
Cuñas estándar de 3/4/5 mm.  
**Fine adjustment**  
With Shims between bracket and ring nut. By replacing/adding calibrated shims, the stroke can be modified.  
Standard shims of 3/4/5 mm.

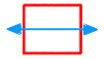

## Diagrama para interruptor de límite (cod. 3/191)

### Diagram for Limit switch (cod. 3/191)

Sensores de posición de deslizamiento lineal hacia adelante y hacia atrás  
(Cantidad : 2 piezas)

Datos técnicos :

- Tipo de salida : PNP
- Tensión de alimentación : 10-30 VDC;
- Máx. corriente de conmutación : 200 mA;
- Rango de temperatura : -25° / 70° C.;



Forward and Backward Linear Slide Position Sensors (Quantity : 2 pcs)  
Technical data :

- Output type : PNP
- Feeding voltage : 10-30 VDC;
- Max. commutating current : 200 mA;
- Temperature range : -25° / 70° C.

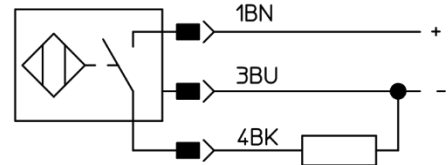

## Diagrama para sensor inductivo CP40.3 (cod. 09538/1/C)

### Diagram for inductive sensor CP40.3 (cod. 09538/1/C)

Sistema de sujeción de sensores SBC Power Clamps para SLDS63.2 y Guías lineales SLDS80.2  
(Cantidad : 2 uds)

Datos técnicos :

- Tipo de salida : PNP
- Voltaje de alimentación : 10-30 VDC;
- Máxima corriente de conmutación : 200 mA;
- Fuente de alimentación : < 25 mA;
- Caída de voltaje : < 2 V
- Rango de temperatura : -25° / 70° C.

Sensors clamping system SBC Power Clamps for SLDS63.2 and SLDS80.2 linear slides (Quantity : 2 pcs)

Technical data:

- Output type : PNP
- Feeding voltage : 10-30 VDC;
- Max. commutating current : 200 mA;
- Power supply : < 25 mA;
- Voltage drop : < 2 V;
- Temperature range : -25° / 70° C.

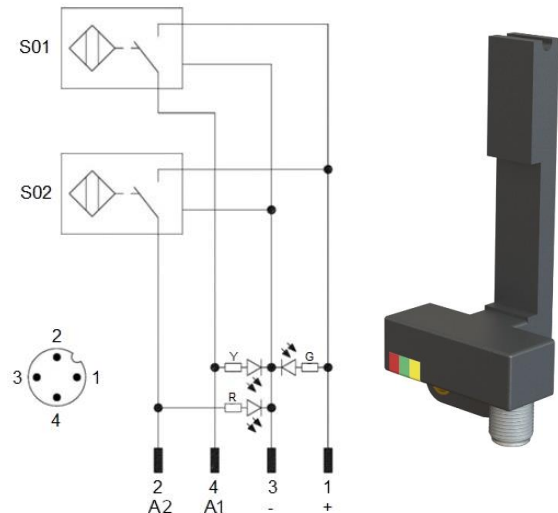

S02 = Señal de cierre  
S02 = Closing signal  
R = LED rojo / red LED

Tensión de trabajo  
Operating voltage  
G = LED verde / green LED

S01 = Señal de apertura  
S01 = Opening signal  
Y = LED amarillo / yellow

**Diagrama para sensor inductivo CP50.1 (cod. 09127/1/C).****Diagram for inductive sensor CP50.1 (cod. 09127/1/C).**

Sensores sistema de sujeción SBC Power Clamps para SLDS125.2 guías lineales (Cantidad : 2 uds)

Datos técnicos :

- Tipo de salida : PNP
- Tensión de alimentación : 10-30 VDC;
- Máxima corriente de conmutación : 200 mA;
- Fuente de alimentación : < 25 mA;
- Caída de voltaje : < 2 V
- Rango de temperatura : -25° / 70° C.

Sensors clamping system SBC Power Clamps for SLDS125.2 linear slides (Quantity : 2 pcs)

Technical data :

- Output type : PNP
- Feeding voltage : 10-30 VDC;
- Max. commutating current : 200 mA;
- Power supply : < 25 mA;
- Voltage drop : < 2 V;
- Temperature range : -25° / 70° C.

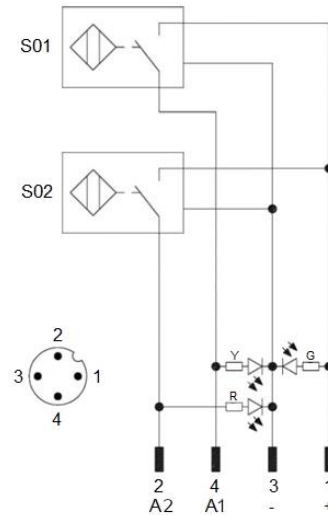

S02 = Señal de cierre

S02 = Closing signal

R = LED rojo / red LED

Tensión de trabajo

Operating voltage

G = LED verde / green LED

S01 = Señal de apertura

S01 = Opening signal

Y = LED amarillo / yellow

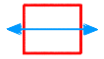

## Diagrama Neumático

### Pneumatic plan.

Válvula de control 5/2

Control valve 5/2

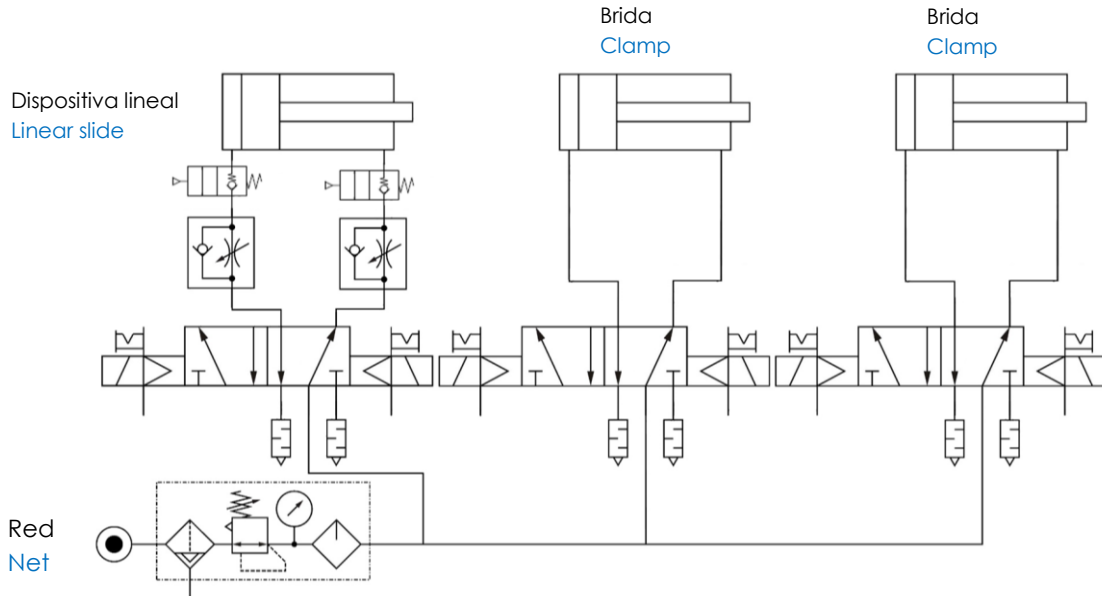

### Consumo de aire.

#### Air consumption

Carrera Stroke	Consumo de aire (5 bar) Air consumption (5 bar)		
	SLDS63.2	SLDS80.2	SLDS125.2
[mm.]	[l]	[l]	[l]
50	3,3	4,4	9,8
100	5,0	7,3	16,8
150	6,8	10,2	23,7
200	8,6	13,0	30,7
300	12,1	18,8	44,7
400	15,7	24,5	58,7
500	19,2	30,2	72,6

Presión de trabajo  
Working pressure

[ bar ]





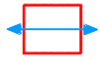

4 – 8

**Notas :** Está solicitando utilizar aire sin lubricar y banco de arena.

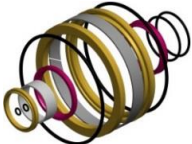

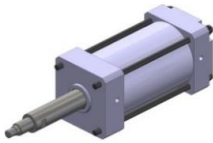
**Note :** It's requesting to use un lubricated air and sand bank.



## Piezas de repuesto. Spare parts.

# Kit	Imagen Picture	Descripción Description		Artículo Article
Kit de sellos Seals kit		SLDS63.2		SCR-SLD63.1
		SLDS80.2		SCR-SLD80.1
		SLDS125.2		SCR-SLD125.1
Cilindro neumático Pneumatic cylinder		SLDS63.2		07657/carrera/C 07657/stroke/C
		SLDS80.2		07669/carrera/C 07669/stroke/C
		SLDS125.2		07736/carrera/C 07736/stroke/C
Sensor inductivo de abrazadera (SBC) Clamp inductive sensor (SBC)		Detector de proximidad inductivo VEP (0°) Inductive proximity switch VEP (0°)		SLDS63.2 SLDS80.2
				SLDS125.2
Barra del sensor Sensor bar		Barra del sensor satelital Sensor satellite bar		SLDS63.2 SLDS80.2
				SLDS125.2
Amplificador de sensores Sensor amplifier		Sensor de potencia amplificador conector M12 0° Power sensor amplifier M12 connector 0°		3/436
Interrupción de límite (Pos) Limit switch (Pos)		SLDS63.2 SLDS 80.2 SLDS125.2		3/191

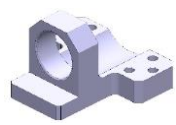
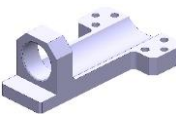

<b>Amortiguador</b> <b>Shock absorber</b>		SLDS63.2 / SLDS80.2		<b>3/119</b>
		SLDS125.2		<b>3/163</b>
<b>Soporte de carrera larga</b> <b>Long stroke bracket</b>		SLDS63.2		<b>07663</b>
		SLDS80.2		<b>07676</b>
		SLDS125.2		<b>07735</b>
<b>Soporte de carrera corta</b> <b>Short stroke bracket</b>		SLDS63.2		<b>08212</b>
		SLDS80.2		<b>08292</b>
		SLDS125.2		<b>07784</b>
<b>Cuñas de ajuste de carrera</b> <b>Stroke adjustment shims</b>		3 mm.		<b>07790/3</b>
		4 mm.		<b>07790/4</b>
		5 mm.		<b>07790/5</b>
<b>Cuñas de ajuste de carrera</b> <b>Stroke adjustment shims</b>		0,5 mm.	SLDS63.2 / SLDS80.2	<b>08598/0,5</b>
			SLDS125.2	<b>09322/0,5</b>
		1 mm.	SLDS63.2 / SLDS80.2	<b>08598/1</b>
			SLDS125.2	<b>09322/1</b>
		2 mm.	SLDS63.2 / SLDS80.2	<b>08598/2</b>
			SLDS125.2	<b>09322/2</b>
<b>Bloques</b> <b>Blocks</b>		SLDS63.2		<b>3/131/R</b>
		SLDS80.2		<b>3/135/R</b>
		SLDS125.2		<b>3/136/R</b>

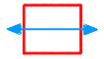

<p><b>Pinza neumática Sistema de bloqueo (SBC)</b></p> <p><b>Pneumatic clamp Locking system (SBC)</b></p>		<p>CP40.3 Brazo G1C  <b>CP40.3 Arm G1C</b>                  (SLDS63.2)</p>	<p><b>CP40.3 G1C I1 - 60</b></p>
		<p>CP40.3 Brazo G1D  <b>CP40.3 Arm G1D</b>                  (SLDS80.2)</p>	<p><b>CP40.3 G1D I1 - 60</b></p>
		<p>CP40.2 Brazo G1S  <b>CP40.2 Arm G1S</b>                  (SLDS80.2)</p>	<p><b>CP40.3 G1S I1 - 60</b></p>
		<p>CP50.1 Brazo G1D  <b>CP50.1 Arm G1D</b>                  (SLDS125.2)</p>	<p><b>CP50.1 G1D I1 - 45</b></p>
		<p>CP50.1 Brazo G1S  <b>CP50.1 Arm G1S</b>                  (SLDS125.2)</p>	<p><b>CP50.1 G1S I1 - 45</b></p>
<p><b>Sellos de abrazaderas Equipo (SBC)</b></p> <p><b>Clamps seals Kit (SBC)</b></p>		<p>SLDS63.2 / SLD80.2</p>	<p><b>SCR-CPL40</b></p>
		<p>SLDS125.2</p>	<p><b>SCR-CPL50</b></p>

